

RoHS
Compliant

ITEM	DESCRIPTION	MATERIAL	Q'TY	FINISHED
1	NUT	BRASS	1	NICKEL PLATED
2	INSULATOR	TEFLON	1	NATURAL
3	GASKET	SILICON	1	RED
4	RETAINER RING	Be.copper	1	NATURAL
5	BODY	BRASS	1	NICKEL PLATED
6	CONTACT PIN	BRASS	1	GOLD PLATED
7	FERRULE	BRASS	1	NICKEL PLATED
8	SUMMER TUBE	----	1	BLACK

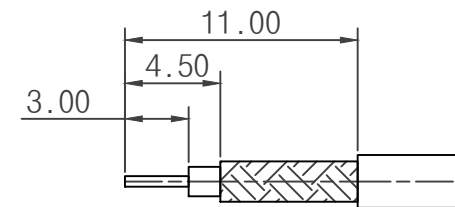
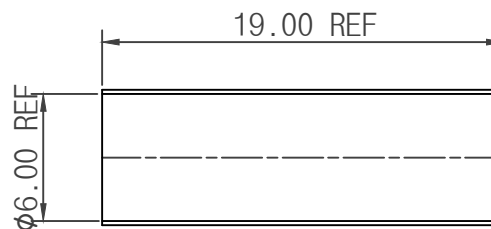
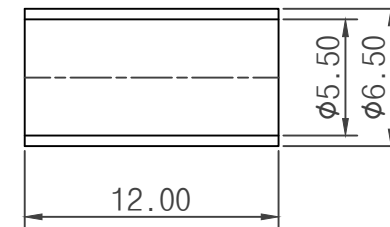
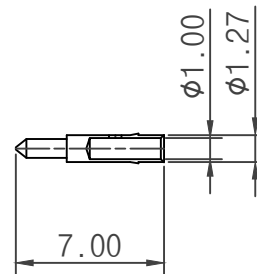
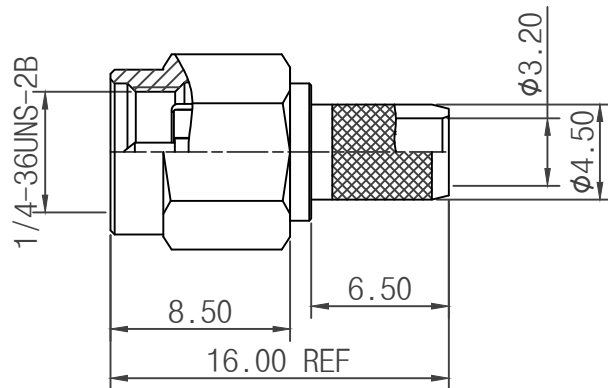
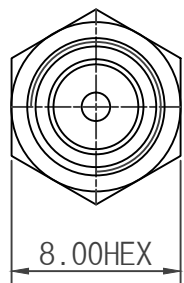

- 1.CRIMPED FERRULE HEX CRIMP SIZE .128"
- 2.CONTACT PIN TO SOLDER

NOTES:FINISH (PLATING THICKNESS IN MICRO-INCHES)
GOLD PL. 3 MICROINCH MINIMUM

RECOMMENDED
CABLE STRIPPING DIM'S

ITEM	Description	Revision	Mender

REMARKS:	REV:	A1	TITLE:		
	DESIGNED:	WYP	SMA MALE CRIMP TO FOR RG55/U RG142/U RG400/U RG223/U, 50 OHM		
	DRAWN:	WYP	ASSEMBLY DRAWING	SCALE:	FIT
	CHECKED:	XXXXX	DWG No: 2103-1A-C0102	SHEET SIZE:	A4
	APPROVAL:	XXXXX	DATE: 2016/03/18	UNITS:	mm
TOLERANCES:		3RD ANGLE Super Yong (Guang Zhou) electronic Co.Ltd www.super-conn.com			
DIM. X.X=±0.5 X.XX=±0.25					